

## BS 5153 PN16 CAST IRON AIR CUSHION SWING CHECK VALVE

### TECHNICAL REQUIREMENT :

- Design and Manufacture Conform to EN12334, BS5153
- Flange dimensions Conform to EN1092-2 PN16
- Face to Face dimensions Conform to EN558-1 List 10, BS5153
- Testing Conform to EN12266-1
- CI-GREY CAST IRON, DI-DUCTILE IRON

### MATERIALS OF PARTS

NO.	PART NAME	MATERIAL
1	BODY	EN-GJL-250/EN-GJS-500-7
2	SEAT RING	ASTM B62 C83600
3	DISC	EN-GJL-250/EN-GJS-500-7
4	CYLINDER APPARATUS	ASSEMBLY
5	DISC RING	ASTM B62 C83600
6	HINGE	ASTM A536 65-45-12
7	STEM	ASTM A276 410
8	BONNET	EN-GJL-250/EN-GJS-500-7
9	LEVER	CARBON STEEL
10	WEIGHT	CAST IRON

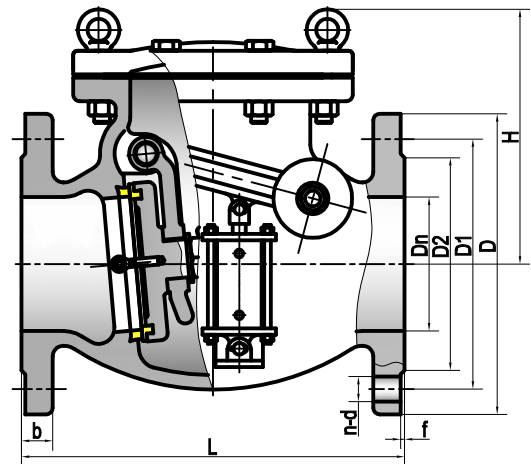

Fig No. :CHV403-PN16

### DIMENSIONS DATA (MM)

DN		200	250	300	350	400	450	500	600
L		495	622	699	787	914	965	1016	1219
D	CI	340	405	460	520	580	640	715	840
	DI		400	455					
D1		295	355	410	470	525	585	650	770
D2		266	319	370	429	480	548	609	720
b	CI	30	32	32	36	38	40	42	48
	DI	20	22	24.5	26.5	28	30	31.5	36
n-d		12-23	12-28	12-28	16-28	16-31	20-31	20-34	20-37
f		3	3	4	4	4	4	4	5
H		332	383	425	450	512	702	755	856